

Revision History

Date	Version	Description
2009 Oct 07	1.0	engineering sample version
2009 Dec 10	1.1	add PERST# delay circuit

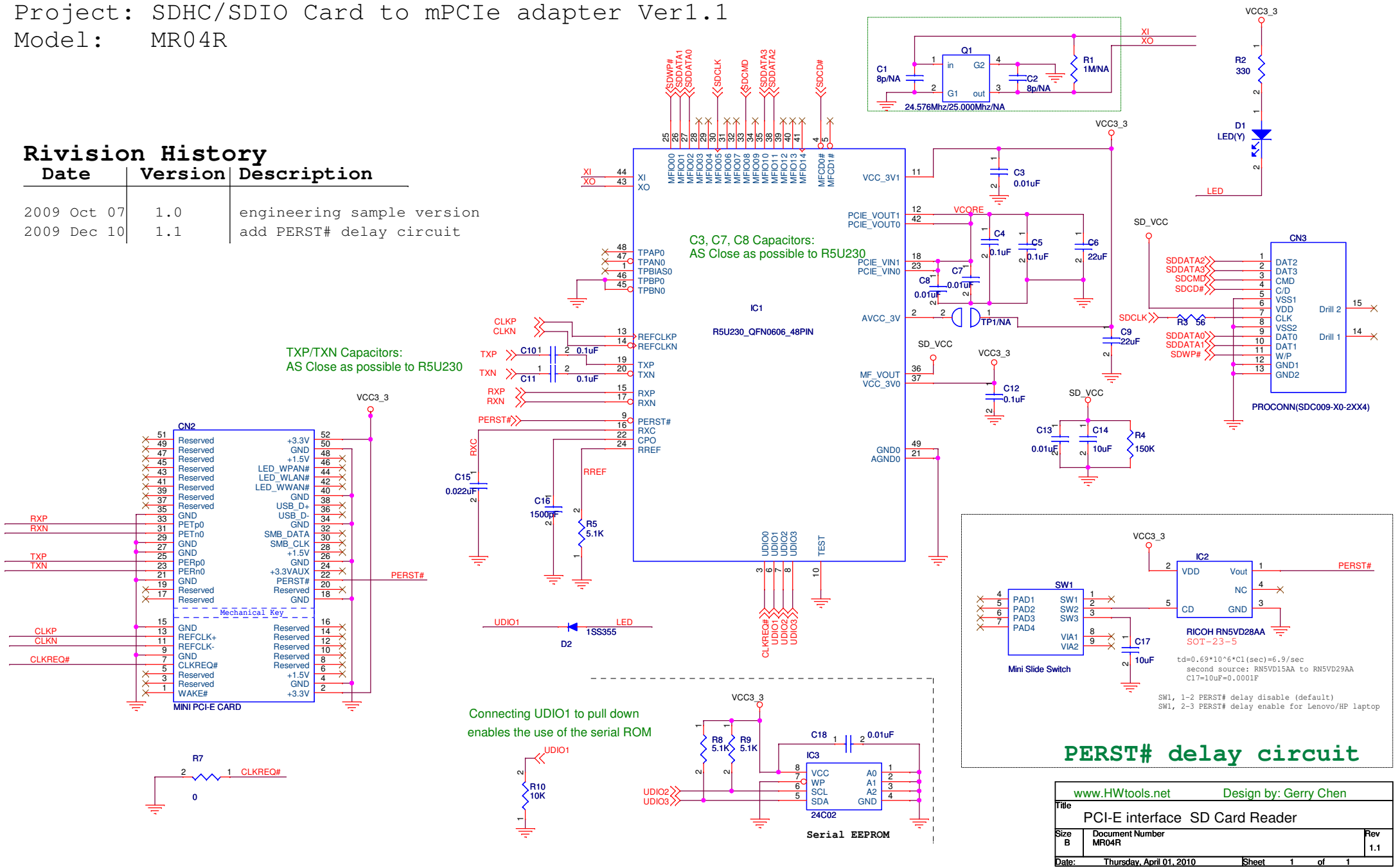

TXP/TXN Capacitors:
AS Close as possible to R5U230

C3, C7, C8 Capacitors:
AS Close as possible to R5U230

Connecting UDIO1 to pull down
enables the use of the serial ROM

PERST# delay circuit

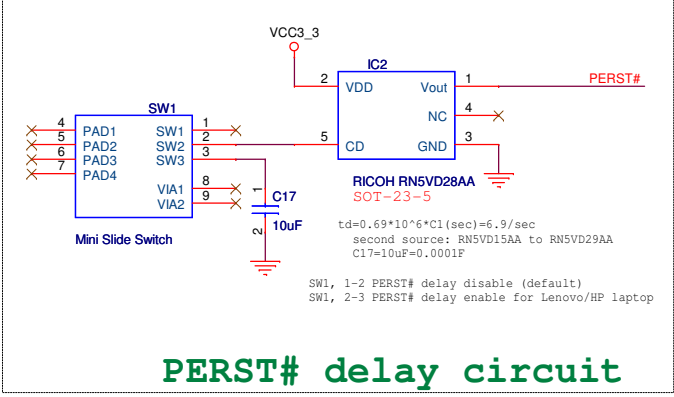

www.HWtools.net		Design by: Gerry Chen	
Title PCI-E interface SD Card Reader			
Size B	Document Number MR04R	Rev 1.1	
Date:	Thursday, April 01, 2010	Sheet	1 of 1