

Model Name: PE4L

Product Name: PCIe to Expresscard adapter

Engineering Sample schematic Ver1.2

Schematic update note:

First released.....2009/June/20 V1.10
 2nd released.....2009/Aug /01 V1.20

Add Floppy +12V, +5V input
 Add USB port
 Change DC/DC to V/R LT1084CT-3.3

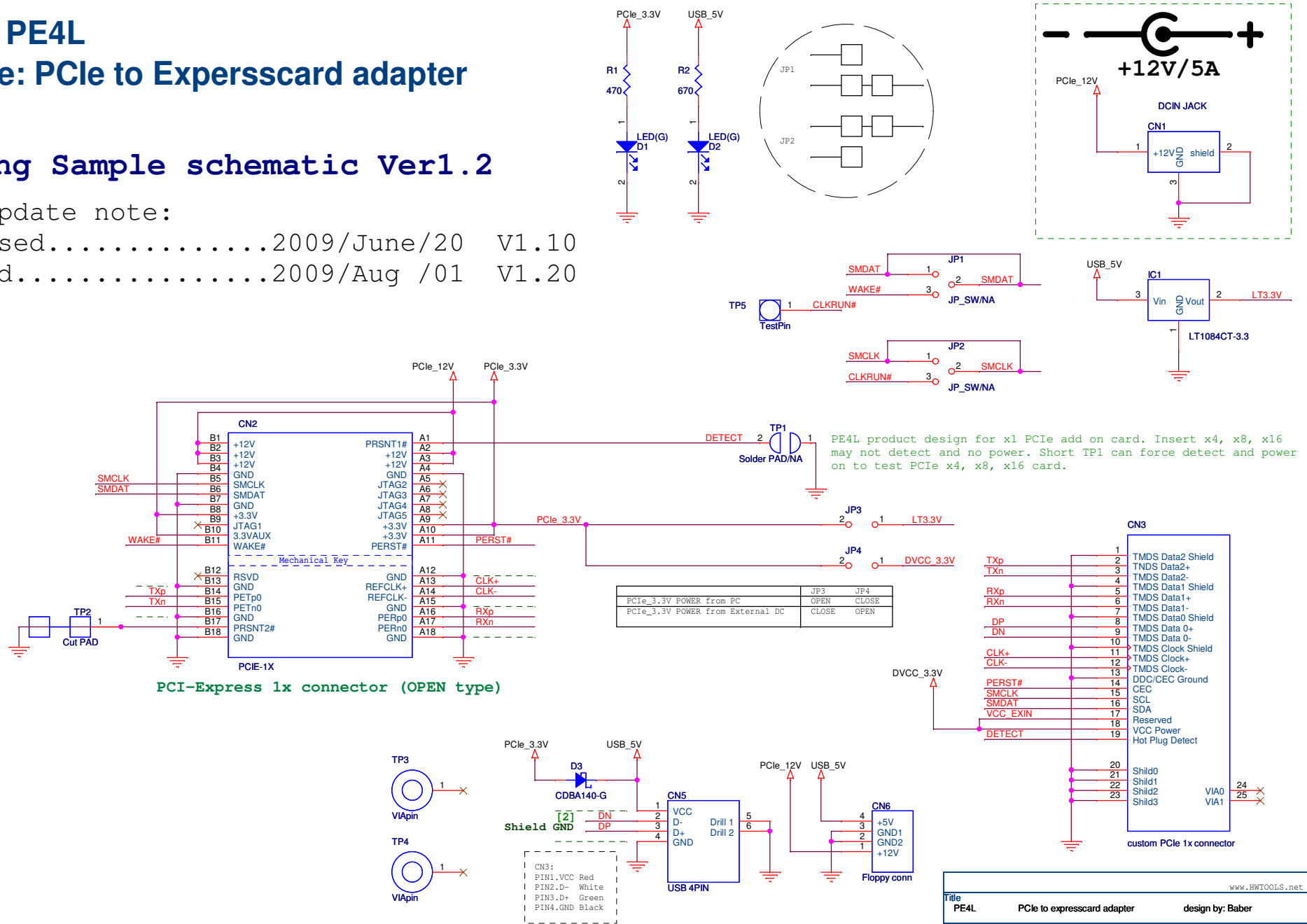

PE4L product design for x1 PCIe add on card. Insert x4, x8, x16 may not detect and no power. Short TP1 can force detect and power on to test PCIe x4, x8, x16 card.

www.HWTOOLS.net			
Title	PE4L PCIe to expresscard adapter		design by: Baber
Size	Document Number	Rev	
B	PCIEX_CARD	Bplus Technology Co., Ltd.	1.20
Date:	Wednesday, September 09, 2009	Sheet	1 of 1