

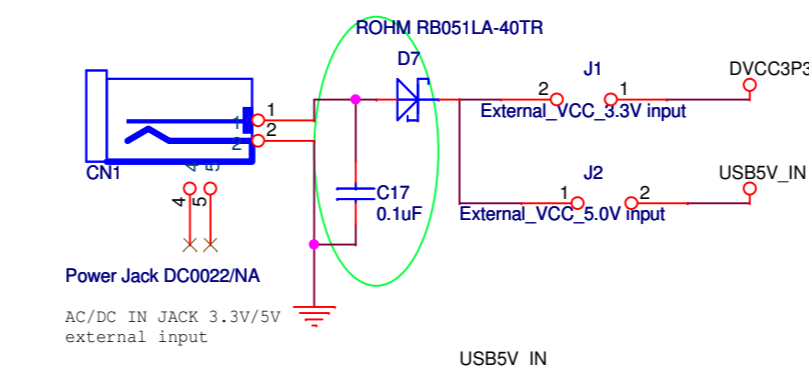

Wireless USB Mini Card Adapter ver1.0

Model:USBMS

[1] Impedance control required for DP DN : 90ohm

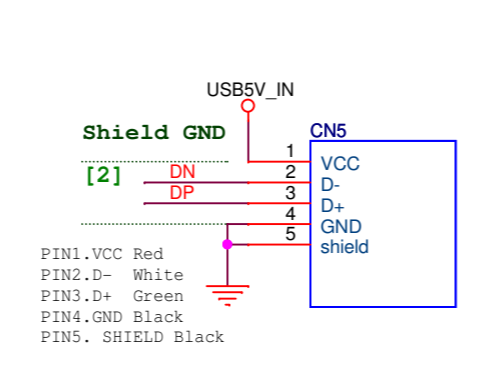
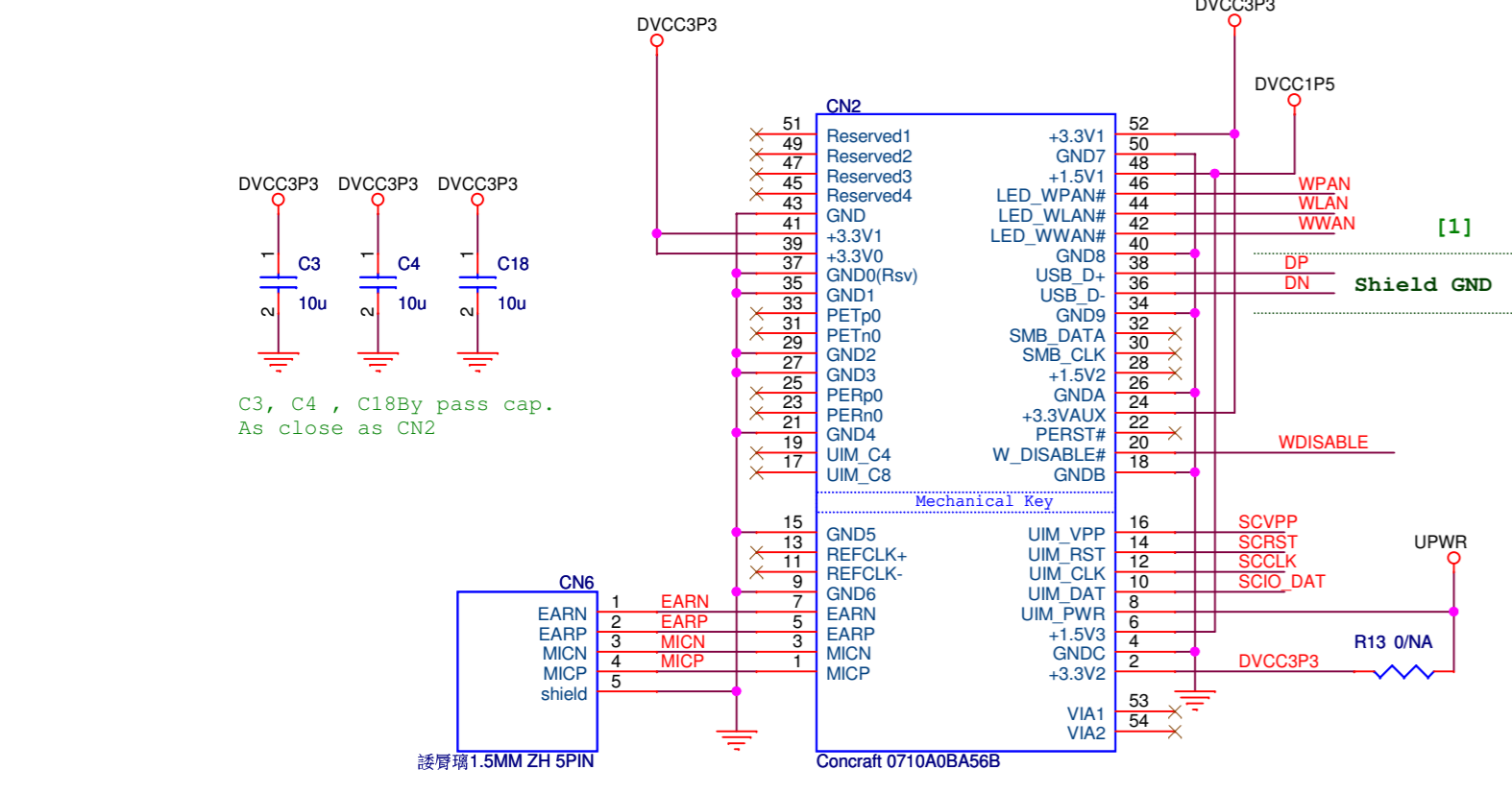

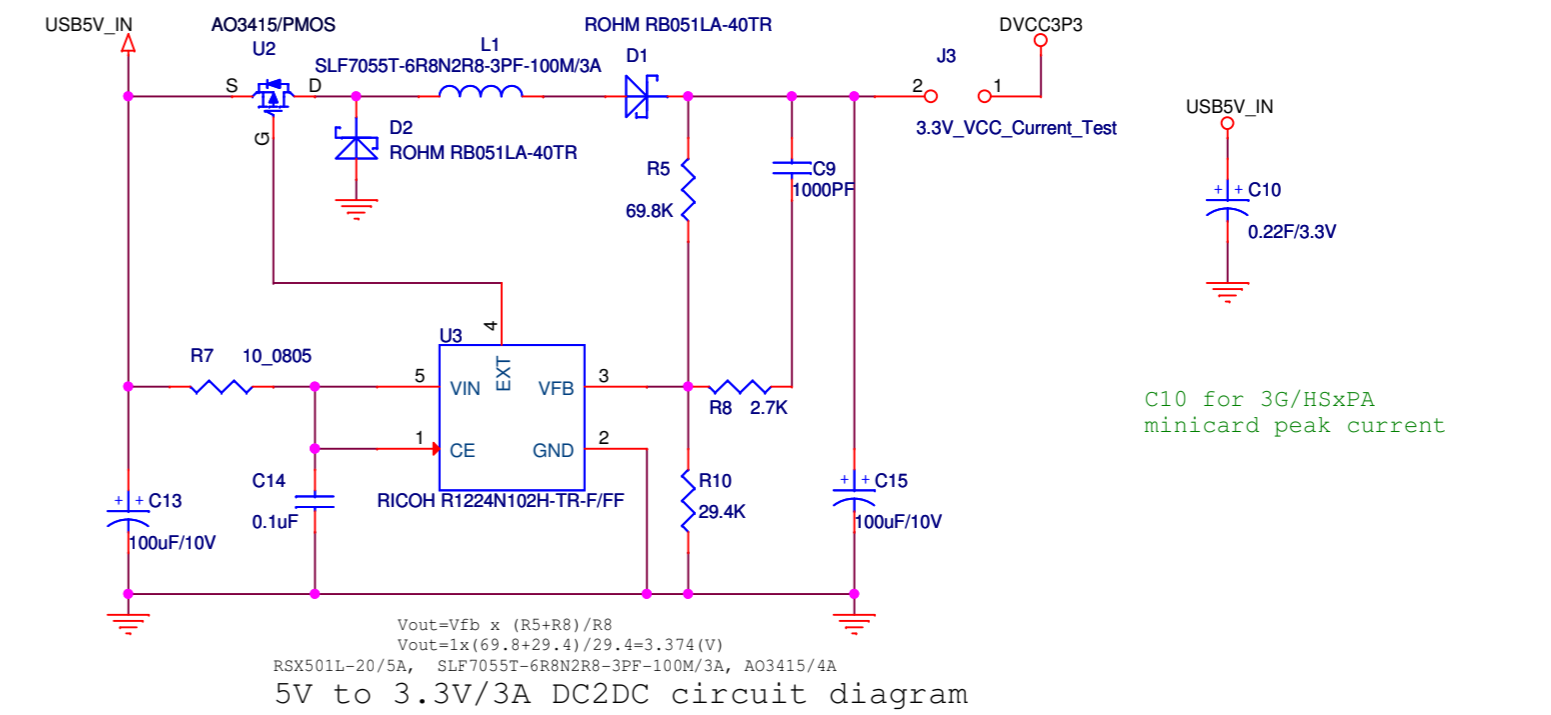
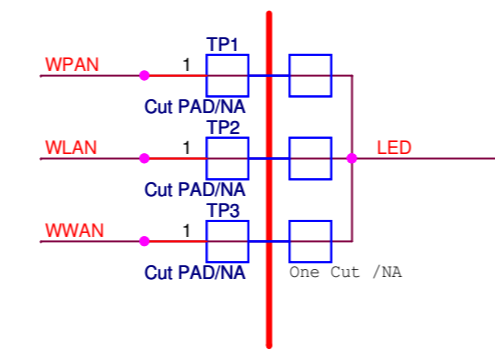
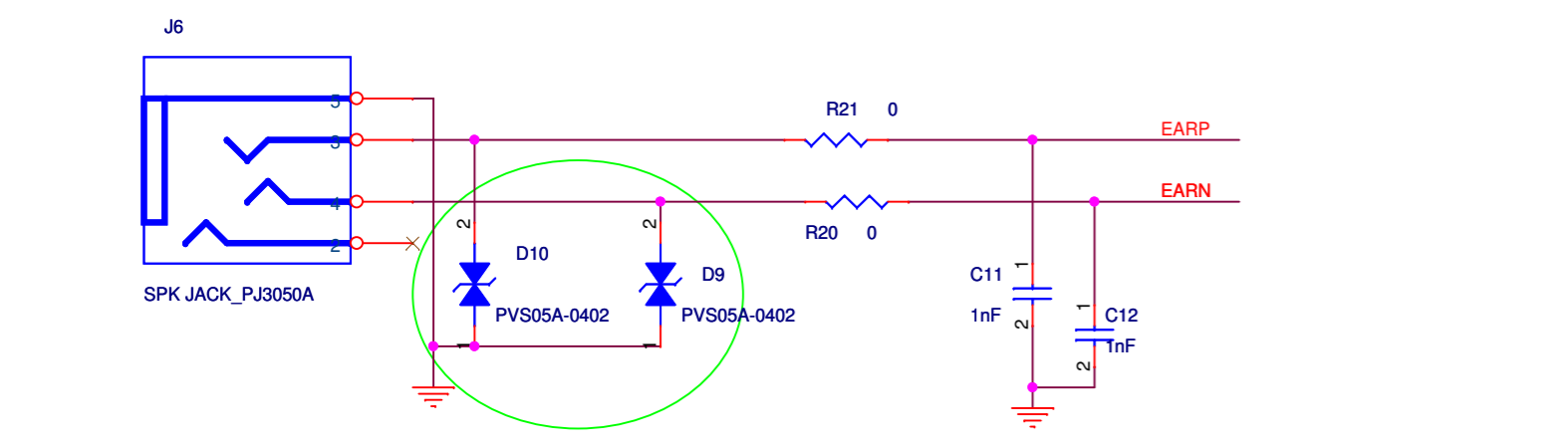
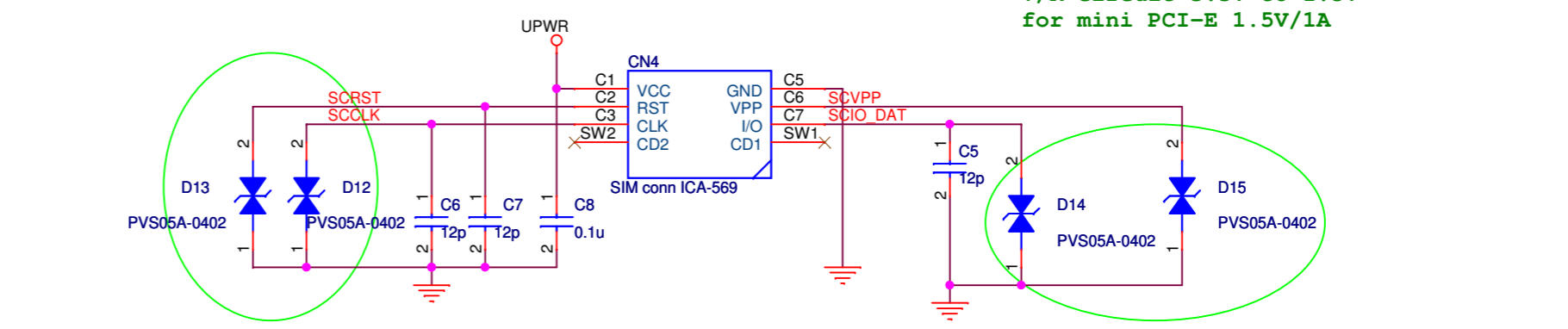
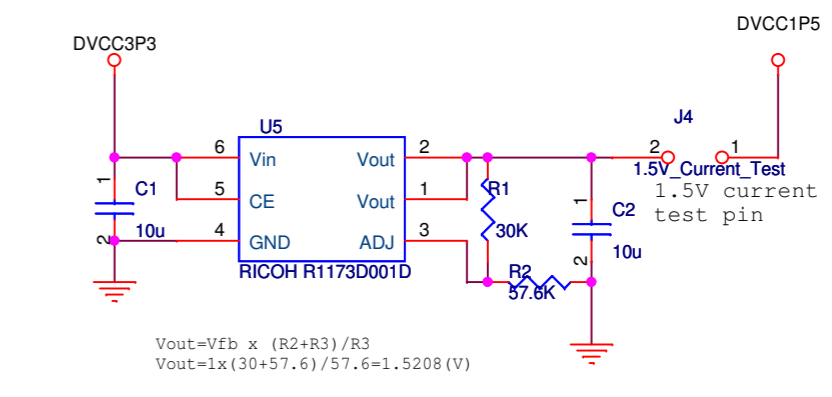
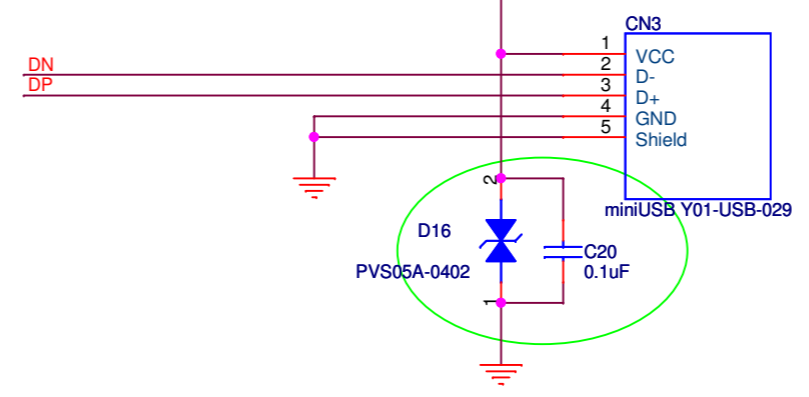

AC100~240V in DC3.3V/2.5A
AC100~240V in DC5.0V/2.5A

DO NOT set J1 and J2 short at the same time.

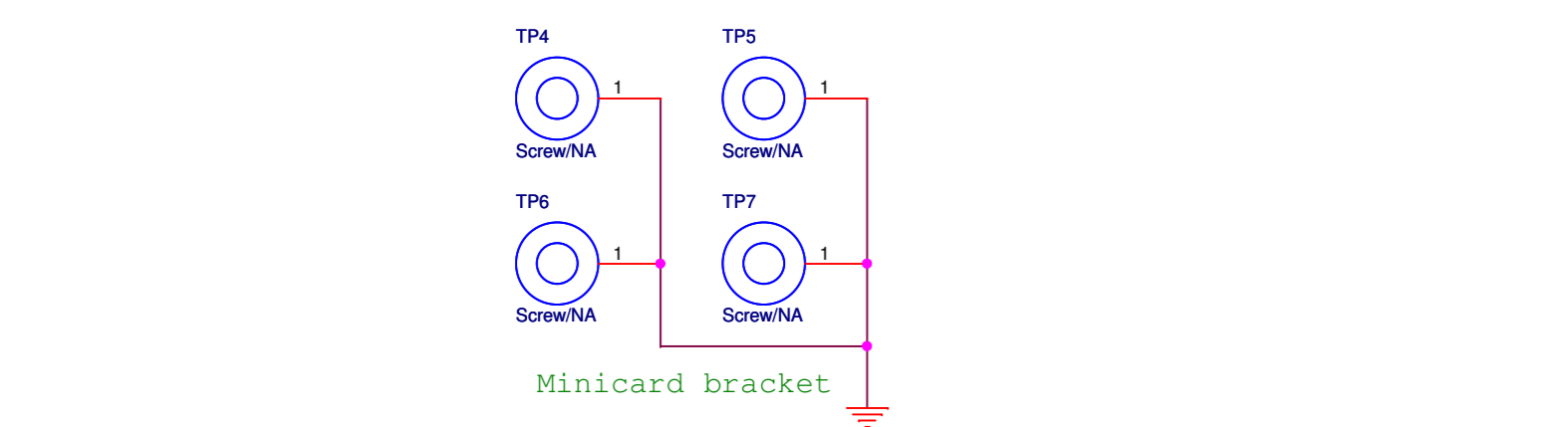
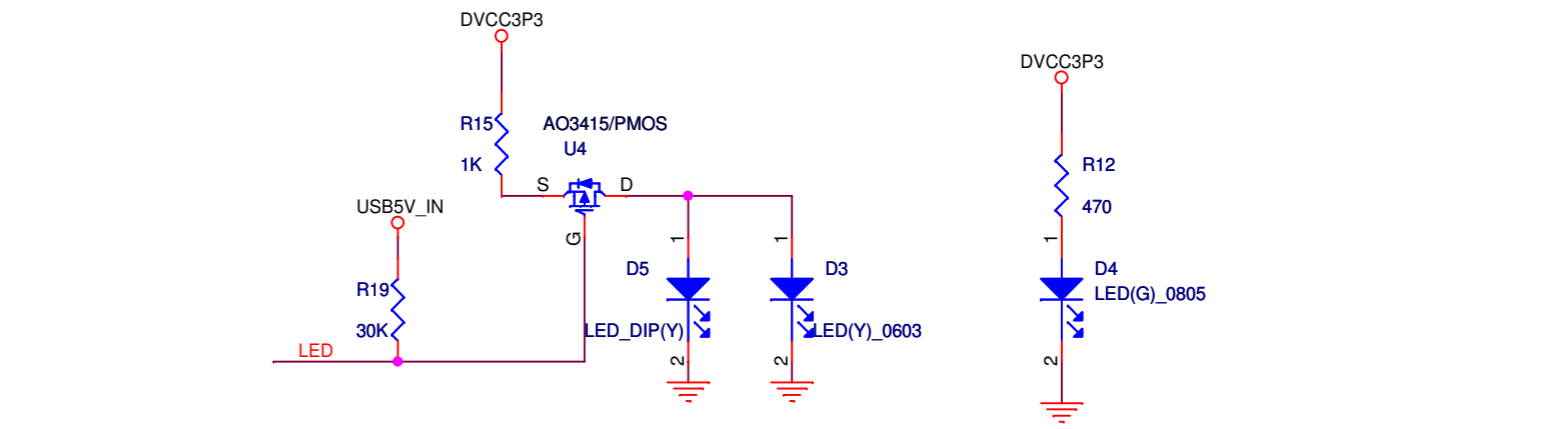
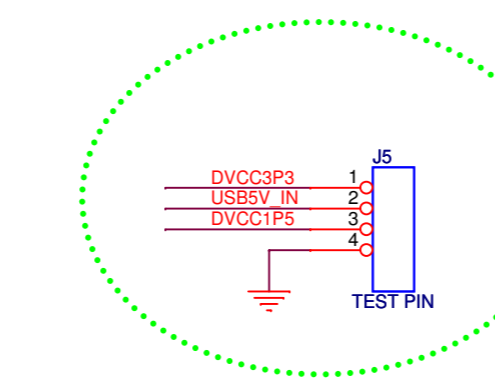
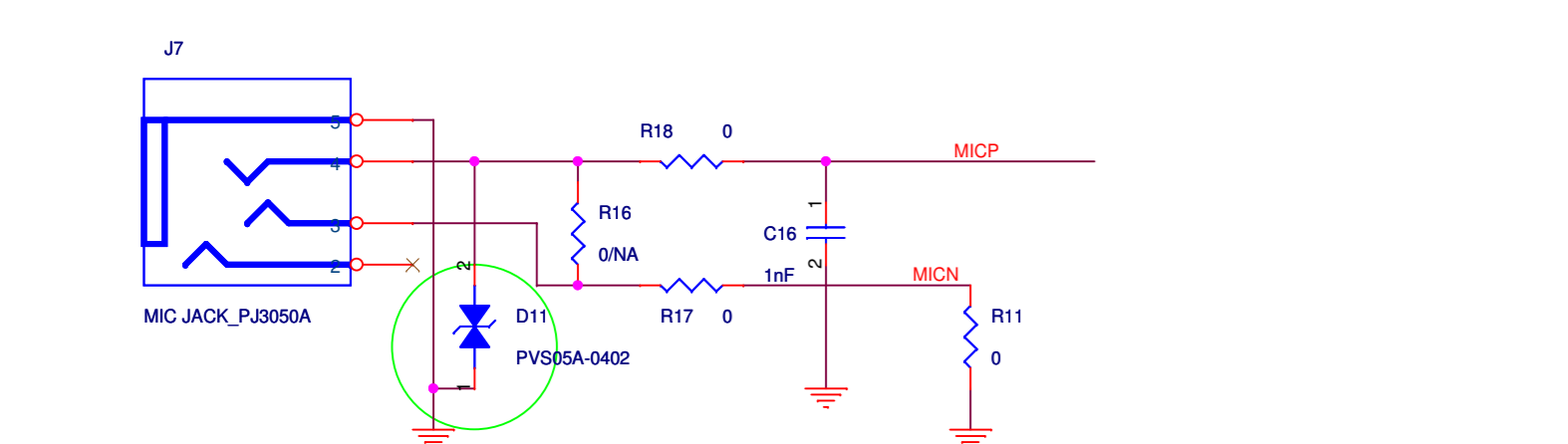

C10 for 3G/HSxPA minicard peak current



JUMP description

| | |
|---------------------------------|-------------------------------|
| J1 External DC 3.3V POWER input | J2 External DC 5V POWER input |
| J3 3.3V current test | J4 1.5V current test |

| DC JACK POWER INPUT select | J1 | J2 |
|----------------------------|-------|-------|
| DC 5.0V IN | OPEN | SHORT |
| DC 3.3V IN (default) | SHORT | OPEN |

DO NOT set J1 & J2 short at the same time.